

Gummi-Metall-Puffer**Butées en métal-caoutchouc**

Gummimischung 55° +/-5°

Werkstoff Stahl (St 37)

Oberfläche gelb verzinkt, Toleranz DIN 7715 M3c.

Andere Härten (45°/65°/75°) und Mischungen (Perbunan und EPDM) sind auf Anfrage erhältlich.

*Mélange de caoutchouc 55° +/-5°**Matériau première acier (St 37)**Surface zinguée jaune, tolérance DIN 7715 M3c.**D'autres duretés (45°/65°/75°) et mélanges (Perbunan et EPDM) sur demande.*

Ausführung / Exécution 1				
Typ	Diam. mm D	Höhe/Hauteur mm H	Gewinde Filetage G x L	
10-10	10	10	M4x10	
15-15	15	15	M4x10	
20-15	20	15	M6x18	
20-20	20	20	M6x18	
25-10	25	10	M6x18	
25-20	25	20	M6x18	
30-20	30	20	M8x20	
30-30	30	30	M8x20	
40-30	40	30	M8x23	
40-40	40	40	M8x23	
50-30	50	30	M10x28	
50-40	50	40	M10x28	
70-45	70	45	M10x28	
75-40	75	40	M12x37	
75-50	75	50	M12x37	
100-40	100	40	M16x41	
100-55	100	55	M16x41	

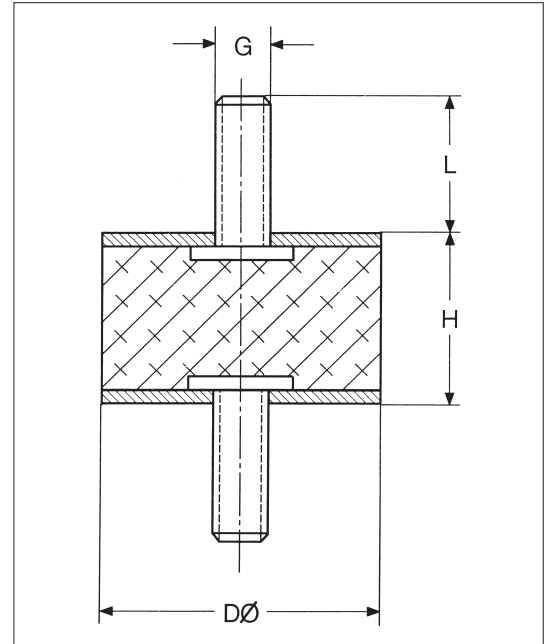

Ausführung / Exécution 2					
Typ	Diam. mm D	Höhe/Hauteur mm H	Gewinde Filetage G x L	Gewindetiefe Longueur filetée G	
10-10	10	10	M4x10	5	
15-15	15	15	M4x10	5	
20-15	20	15	M6x18	6	
25-15	25	15	M6x18	6	
25-20	25	20	M6x18	6	
30-20	30	20	M8x20	8	
30-30	30	30	M8x20	8	
40-30	40	30	M8x23	8	
40-40	40	40	M8x23	8	
50-30	50	30	M10x28	10	
50-40	50	40	M10x28	10	
50-45	50	45	M10x28	12	
60-40	60	40	M10x28	10	
70-45	70	45	M10x28	10	
75-40	75	40	M12x37	12	
75-50	75	50	M12x37	12	
100-40	100	40	M16x41	16	
100-55	100	55	M16x41	16	

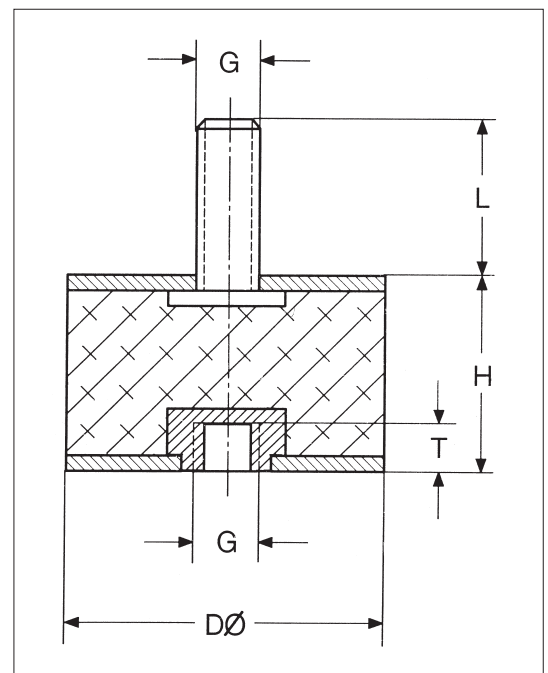

Gummi-Metall-Puffer

Butées en métal-caoutchouc

Ausführung / Exécution 3				
Typ	Diam. mm D	Höhe/Hauteur mm H	Gewinde Filetage G x L	Gewindetiefe Longueur fileté G
15-15	15	15	M4	5
20-20	20	20	M6	6
25-20	25	20	M6	6
30-20	30	20	M8	8
30-30	30	30	M8	8
30-40	30	40	M8	8
40-30	40	30	M8	8
50-30	50	30	M10	10
50-45	50	45	M10	10
50-50	50	50	M10	10
60-40	60	40	M10	10
75-50	75	50	M12	12
80-80*	80	80	M12	12
100-55	100	55	M16	16
100-100*	100	100	M16	16
125-100*	125	100	M16	16
150-120*	150	120	M16	16

* Härte/Dureté 45°

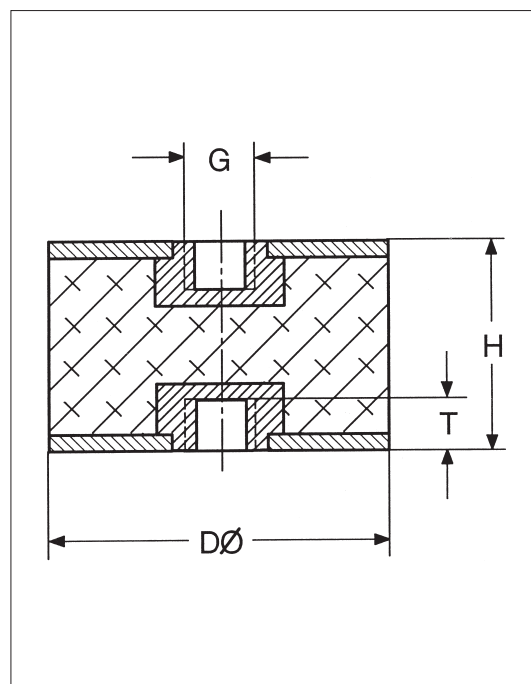

Ausführung / Exécution 4			
Typ	Diam. mm D	Höhe/Hauteur mm H	Gewinde Filetage G x L
20-15	20	15	M6x18
30-20	30	20	M8x20
30-30	30	30	M8x20
40-20	40	20	M8x23
40-30	40	30	M8x23
50-20	50	20	M10x28
50-30	50	30	M10x28
75-25	75	25	M12x27
75-40	75	40	M12x37
100-40	100	40	M16x41

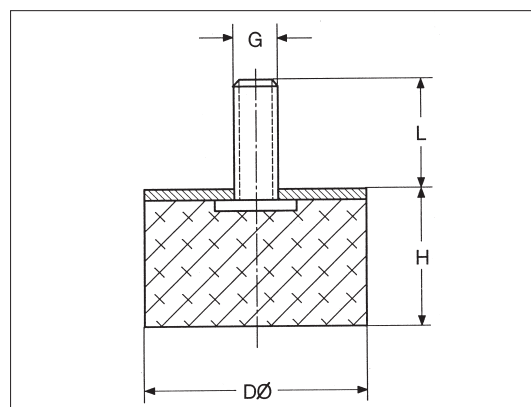

Gummi-Metall-Anschlagpuffer

Tampons butoires en métal-caoutchouc

Typ	Diam. mm D	Höhe/Hauteur mm H	Gewinde Filetage G x L
AK-25-17-4**	25	17	M6x18
AK-50-17-4**	50	17	M10x28

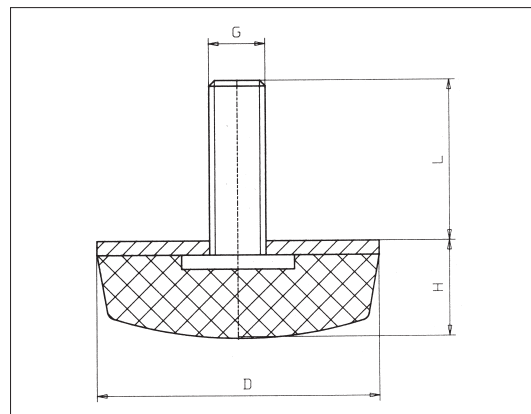

** solange lieferbar / dans la limite des stocks disponibles